

X069/701

NATIONAL
QUALIFICATIONS
2006

WEDNESDAY, 17 MAY
1.00 PM – 3.30 PM

PHYSICS
ADVANCED HIGHER

Reference may be made to the Physics Data Booklet.

Answer **all** questions.

Any necessary data may be found in the Data Sheet on page two.

Care should be taken to give an appropriate number of significant figures in the final answers to calculations.

Square-ruled paper (if used) should be placed inside the front cover of the answer book for return to the Scottish Qualifications Authority.



DATA SHEET
COMMON PHYSICAL QUANTITIES

Quantity	Symbol	Value	Quantity	Symbol	Value
Gravitational acceleration on Earth	g	9.8 m s^{-2}	Mass of electron	m_e	$9.11 \times 10^{-31} \text{ kg}$
Radius of Earth	R_E	$6.4 \times 10^6 \text{ m}$	Charge on electron	e	$-1.60 \times 10^{-19} \text{ C}$
Mass of Earth	M_E	$6.0 \times 10^{24} \text{ kg}$	Mass of neutron	m_n	$1.675 \times 10^{-27} \text{ kg}$
Mass of Moon	M_M	$7.3 \times 10^{22} \text{ kg}$	Mass of proton	m_p	$1.673 \times 10^{-27} \text{ kg}$
Mean Radius of Moon Orbit		$3.84 \times 10^8 \text{ m}$	Mass of alpha particle	m_α	$6.645 \times 10^{-27} \text{ kg}$
Universal constant of gravitation	G	$6.67 \times 10^{-11} \text{ m}^3 \text{ kg}^{-1} \text{ s}^{-2}$	Charge on alpha particle		$3.20 \times 10^{-19} \text{ C}$
Speed of light in vacuum	c	$3.0 \times 10^8 \text{ m s}^{-1}$	Planck's constant	h	$6.63 \times 10^{-34} \text{ J s}$
Speed of sound in air	v	$3.4 \times 10^2 \text{ m s}^{-1}$	Permittivity of free space	ϵ_0	$8.85 \times 10^{-12} \text{ F m}^{-1}$
			Permeability of free space	μ_0	$4\pi \times 10^{-7} \text{ H m}^{-1}$

REFRACTIVE INDICES

The refractive indices refer to sodium light of wavelength 589 nm and to substances at a temperature of 273 K.

Substance	Refractive index	Substance	Refractive index
Diamond	2.42	Glycerol	1.47
Glass	1.51	Water	1.33
Ice	1.31	Air	1.00
Perspex	1.49	Magnesium Fluoride	1.38

SPECTRAL LINES

Element	Wavelength/nm	Colour	Element	Wavelength/nm	Colour
Hydrogen	656	Red	Cadmium	644	Red
	486	Blue-green		509	Green
	434	Blue-violet		480	Blue
	410	Violet	<i>Lasers</i>		
	397	Ultraviolet	Element	Wavelength/nm	Colour
	389	Ultraviolet	Carbon dioxide	9550 } 10590 }	Infrared
Sodium	589	Yellow	Helium-neon	633	Red

PROPERTIES OF SELECTED MATERIALS

Substance	Density/ kg m^{-3}	Melting Point/ K	Boiling Point/ K	Specific Heat Capacity/ $\text{J kg}^{-1} \text{ K}^{-1}$	Specific Latent Heat of Fusion/ J kg^{-1}	Specific Latent Heat of Vaporisation/ J kg^{-1}
Aluminium	2.70×10^3	933	2623	9.02×10^2	3.95×10^5
Copper	8.96×10^3	1357	2853	3.86×10^2	2.05×10^5
Glass	2.60×10^3	1400	6.70×10^2
Ice	9.20×10^2	273	2.10×10^3	3.34×10^5
Glycerol	1.26×10^3	291	563	2.43×10^3	1.81×10^5	8.30×10^5
Methanol	7.91×10^2	175	338	2.52×10^3	9.9×10^4	1.12×10^6
Sea Water	1.02×10^3	264	377	3.93×10^3
Water	1.00×10^3	273	373	4.19×10^3	3.34×10^5	2.26×10^6
Air	1.29
Hydrogen	9.0×10^{-2}	14	20	1.43×10^4	4.50×10^5
Nitrogen	1.25	63	77	1.04×10^3	2.00×10^5
Oxygen	1.43	55	90	9.18×10^2	2.40×10^5

The gas densities refer to a temperature of 273 K and a pressure of $1.01 \times 10^5 \text{ Pa}$.

[BLANK PAGE]

[Turn over for Question 1 on *Page four*

1. A child's toy consists of a model aircraft attached to a light cord. The aircraft is swung in a vertical circle **at constant speed** as shown in Figure 1.

X is the highest point and Y the lowest point in the circle.

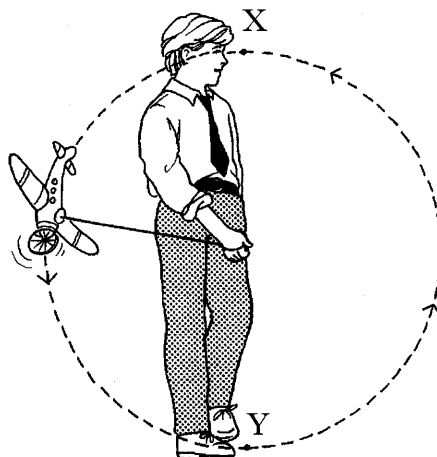

Figure 1

- (a) The time taken for the aircraft to complete 20 revolutions is measured five times.

The mass of the aircraft and the radius of the circle are also measured. The following data is obtained.

Time for 20 revolutions: 10.05 s; 9.88 s; 10.30 s; 9.80 s; 9.97 s.

Radius of circle = 0.500 ± 0.002 m.

Mass of aircraft = 0.200 ± 0.008 kg.

- (i) (A) Calculate the average period of revolution of the aircraft. 3
 (B) Assuming that the scale reading uncertainty and the calibration uncertainty of the timer are negligible, calculate the absolute uncertainty in the period. 3
- (ii) Show that the centripetal force acting on the aircraft is 15.8 N. 2
- (iii) Calculate the absolute uncertainty in this value for the centripetal force. Express your answer in the form $F = (15.8 \pm \quad) \text{N}$. 4
- (iv) Draw labelled diagrams to show the forces acting on the aircraft:
 (A) at position X;
 (B) at position Y. 2
- (v) Calculate the minimum tension in the cord. 2

1. (continued)

- (b) The aircraft has a small air siren which produces a note of frequency 1000 Hz.

One student swings the aircraft in a vertical circle at constant speed. A second student listens to the note while standing in front of the first student, as shown in Figure 2.

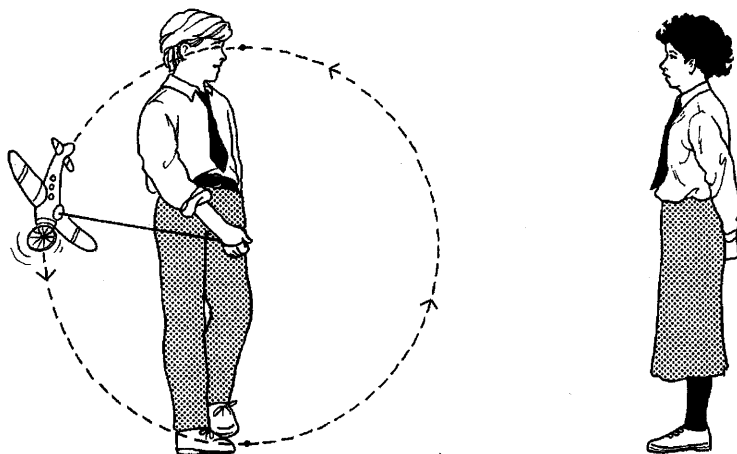

Figure 2

State what happens to the pitch of the note heard by the second student as the aircraft passes through its highest point.

1
(14)

[Turn over

2. A circular metal disc is mounted horizontally on the axle of a rotational motion sensor as shown in Figure 3.

The axle is on a frictionless bearing.

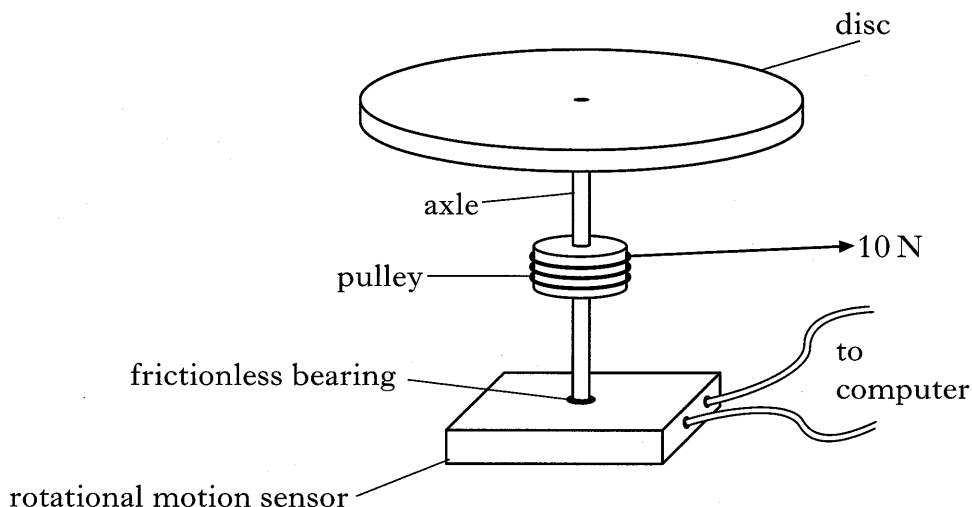

Figure 3

A thin cord is wound round a light pulley which is attached to the axle. The pulley has a radius of 20 mm and a force of 10 N is applied to the free end of the cord.

The cord fully unwinds from the pulley in a time of 3.0 s.

The rotational motion sensor is interfaced to a computer which is programmed to display a graph showing the variation of the angular velocity of the metal disc with time.

The graph displayed on the monitor is shown in Figure 4.

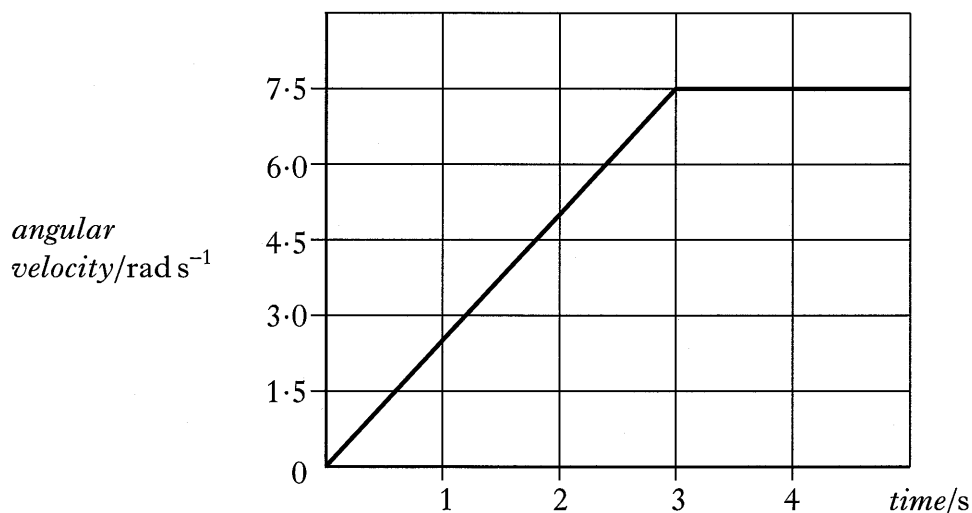

Figure 4

- (a) (i) Calculate the torque exerted by the cord. 2
- (ii) Using information from the graph, determine the angular acceleration of the disc. 2
- (iii) Calculate the moment of inertia of the disc. 2

2. (continued)

- (b) After the cord is fully unwound, a second uniform disc with mass 3.2 kg and radius 0.12 m is gently dropped on top of the original disc as shown in Figure 5.

Both discs now rotate with a new angular velocity.

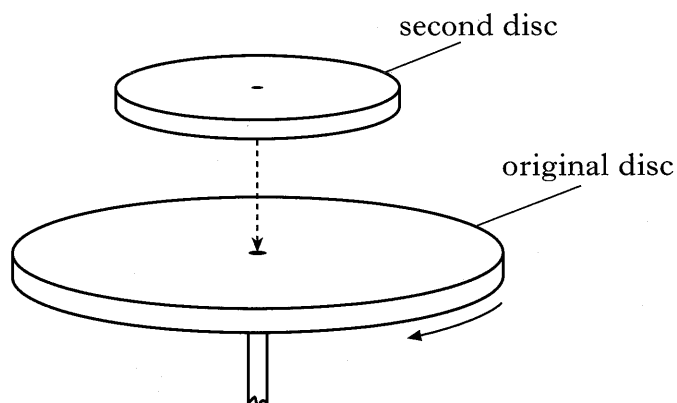

Figure 5

- (i) Calculate the moment of inertia of the second disc. 2
- (ii) Calculate the new angular velocity of the discs. 2
- (c) The experiment is repeated, except that a **ring**, with the same mass and diameter as the second disc, is gently dropped on top of the original disc as shown in Figure 6.

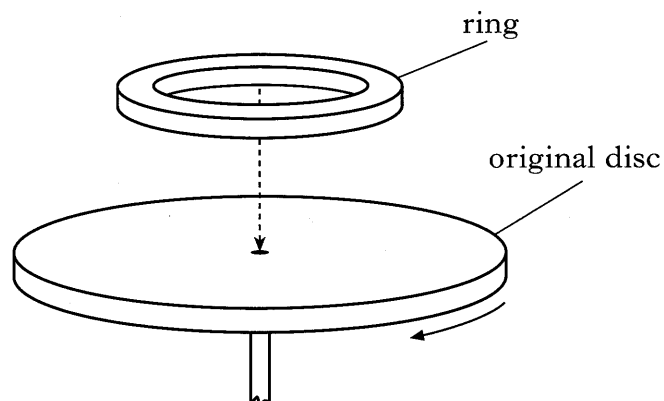

Figure 6

State whether the resulting angular velocity is greater than, less than or the same as that calculated in (b)(ii).

You must justify your answer.

2
(12)

[Turn over

3. (a) (i) State what is meant by *gravitational field strength*. 1
- (ii) The gravitational field strength at the surface of Mars is 3.7 N kg^{-1} .
The radius of Mars is $3.4 \times 10^3 \text{ km}$.
- (A) Use Newton's universal law of gravitation to show that the mass of Mars is given by the equation

$$M = \frac{gr^2}{G}$$

where the symbols have their usual meaning.

- (B) Calculate the mass of Mars. 3
- (b) A spacecraft of mass 100 kg is in circular orbit 300 km above the surface of Mars.
- (i) Show that the force exerted by Mars on the spacecraft is $3.1 \times 10^2 \text{ N}$. 2
- (ii) Calculate the period of the spacecraft's orbit. 3

(9)

4. A test tube contains lead shot. The combined mass of the test tube and the lead shot is 0.250 kg.

The test tube is gently dropped into a container of water and oscillates above and below its equilibrium position with simple harmonic motion as shown in Figure 7.

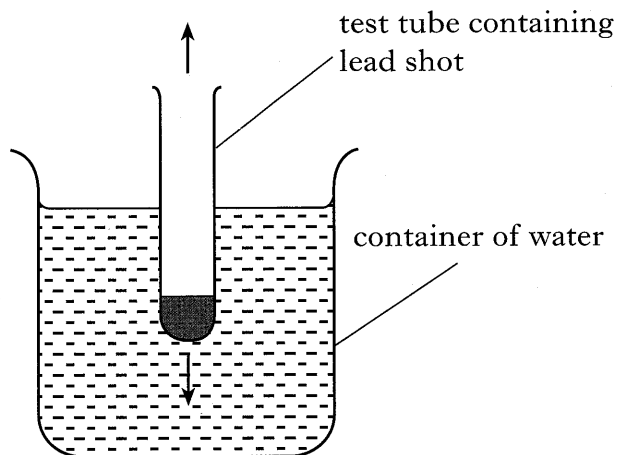

Figure 7

The displacement y of the test tube from its equilibrium position is described by the equation

$$y = 0.05 \cos 6t$$

where y is in metres and t is in seconds.

- (a) Show that the kinetic energy of the test tube, in joules, is given by the equation

$$E_k = 4.5 (2.5 \times 10^{-3} - y^2). \quad 2$$

- (b) Calculate the maximum value of the kinetic energy of the test tube. 1

- (c) Calculate the potential energy of the test tube when it is 40 mm above its equilibrium position. 2
- (5)**

[Turn over

5. (a) A charged metal sphere has a diameter of 0.36 m. The electrostatic potential at the surface of the sphere is $+2.8 \times 10^5$ V.

(i) Show that the charge on the sphere is $+5.6 \times 10^{-6}$ C. 2

(ii) State the electrostatic potential at a point 0.10 m from the **centre** of the sphere. 1

(iii) (A) Calculate the electric field strength at the surface of the sphere.

(B) Sketch a graph of the electric field strength against distance from the centre of the sphere to a point well beyond the sphere's surface. No numerical values are required. 3

(b) Two identical spheres, each carrying a charge of $+5.6 \times 10^{-6}$ C, are now placed as shown in Figure 8.

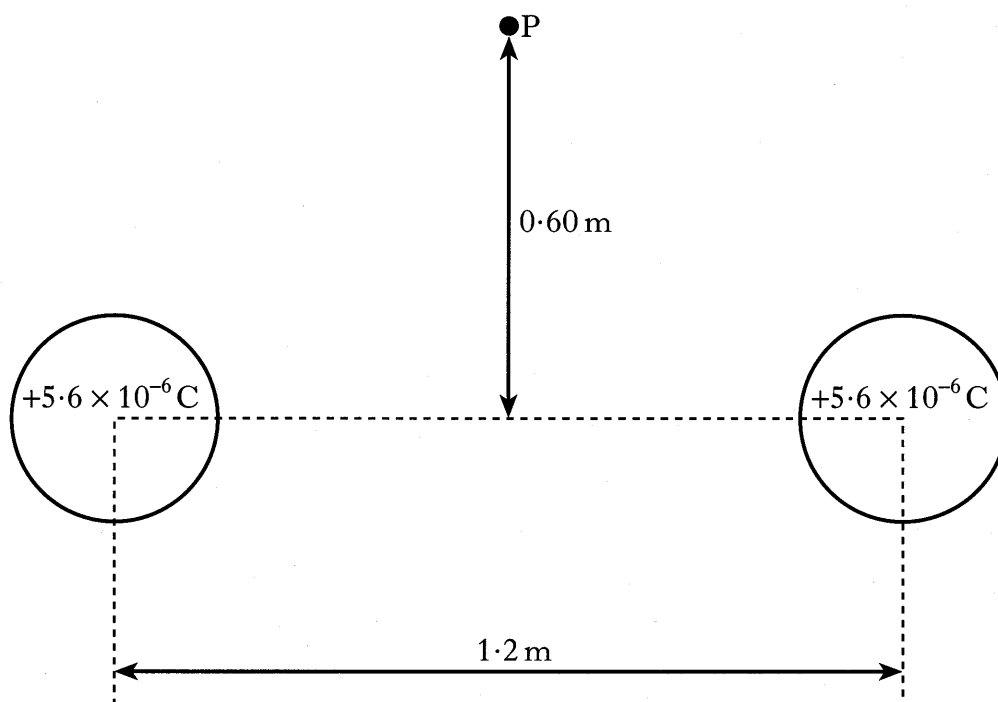

Figure 8

Point P is 0.60 m vertically above the mid-point of the line joining the centres of the two spheres.

Determine the magnitude and direction of the electric field strength at point P. 4

(10)

6. The print head of an ink-jet printer fires a tiny drop of ink of mass 1.2×10^{-12} kg as it scans across the paper. The drop carries a charge of -1.6×10^{-12} C and enters the space between a pair of parallel plates at a speed of 20 m s^{-1} , as shown in Figure 9.

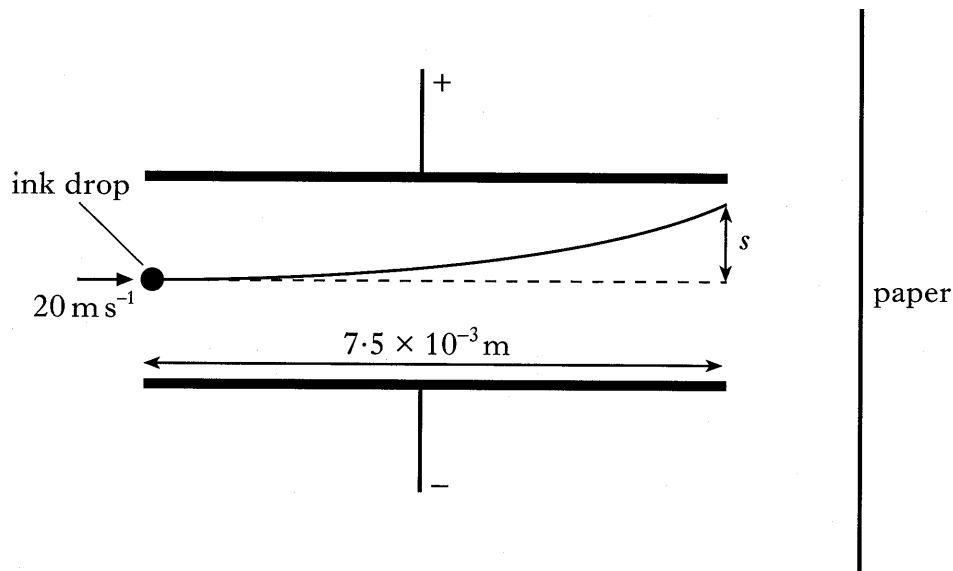

Figure 9

The length of the plates is 7.5×10^{-3} m and the electric field strength between them is $2.5 \times 10^4 \text{ N C}^{-1}$.

- (a) Calculate the magnitude of the electrostatic force acting on the ink drop as it passes between the plates. 2
- (b) Show, by calculation, that the gravitational force acting on the drop is negligible compared to the electrostatic force. 2
- (c) Calculate the deflection s of the drop as it leaves the region between the plates. 4
- (d) Calculate the number of excess electrons on the ink drop. 2
- (10)**

[Turn over

7. (a) (i) A cyclotron is a particle accelerator which consists of two D-shaped hollow structures, called “dees”, placed in a vacuum. Figure 10 shows an arrangement for a cyclotron.

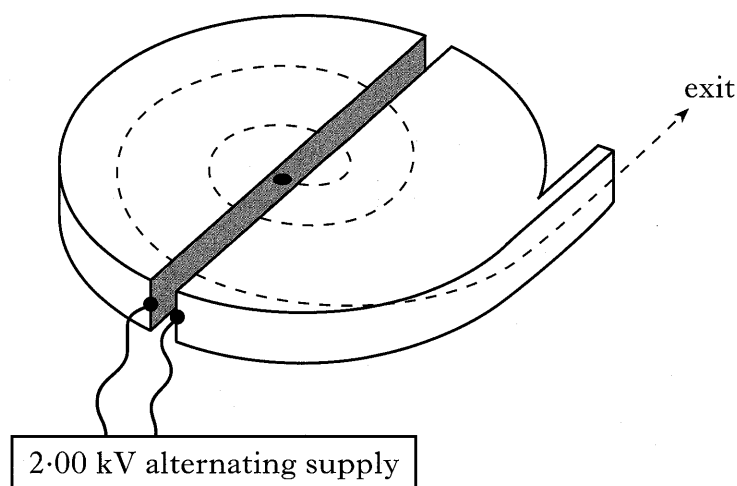

Figure 10

Figure 11 shows the cyclotron viewed from above.

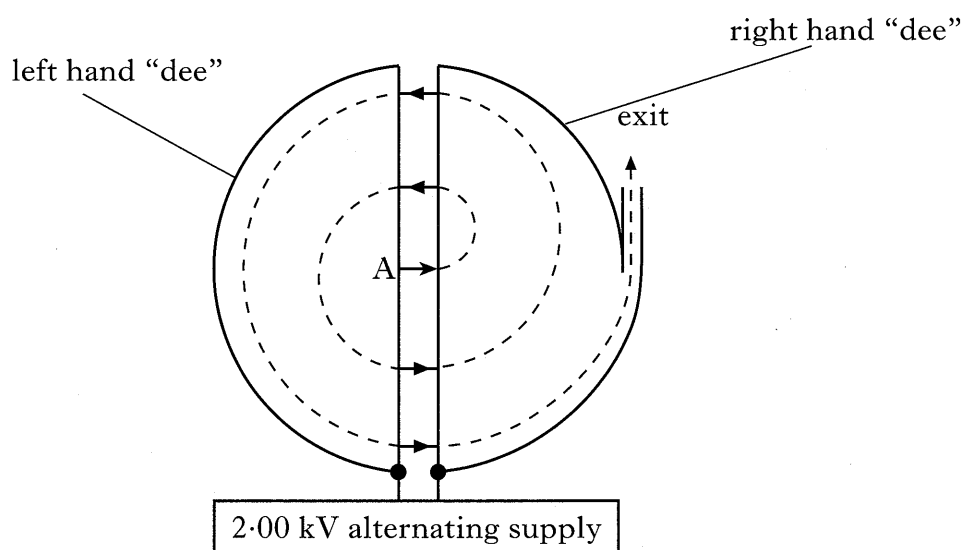

Figure 11

Protons are released from rest at point A and accelerated across the gap between the “dees” by a voltage of 2.00 kV.

Show that the speed of the protons as they **first** reach the right hand “dee” is $6.19 \times 10^5 \text{ m s}^{-1}$.

2

- (ii) Inside the “dees” the electric field strength is zero but a uniform magnetic field of 1.30 T acts perpendicularly to the “dees”. This forces the protons to move in semi-circular paths when inside the “dees”.

Calculate the radius of the **first** such path in the right hand “dee”.

3

7. (a) (continued)

- (iii) While the protons are inside the “dee”, the polarity of the applied voltage is reversed so that the protons are again accelerated when they cross to the left hand “dee”.

Calculate the speed of the protons as they **first** enter the left hand “dee”.

2

- (b) The protons exit the cyclotron with a kinetic energy of $1.57 \times 10^{-13} \text{ J}$ and are aimed at a gold target. The charge on a gold nucleus is $+79e$.

Find the distance of closest approach to a gold nucleus for a proton from this cyclotron.

3

- (c) A larger accelerator produces protons with a **relativistic mass** of $4.66 \times 10^{-27} \text{ kg}$.

Calculate the speed of these protons.

2

(12)

[Turn over

8. A datalogger is used to investigate the rate of change of current in the circuit shown in Figure 12.

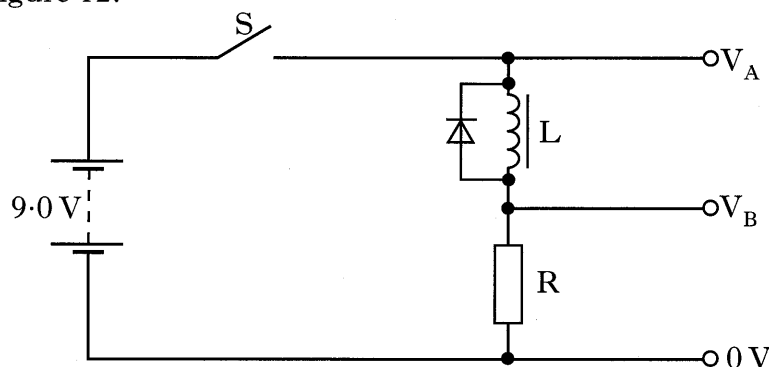

Figure 12

- (a) The datalogger measures the potential V_A and the potential V_B .
 What other piece of information is required to allow the computer software to determine the current in the circuit? 1
- (b) The switch S is closed and the datalogger software produces the graph shown in Figure 13.

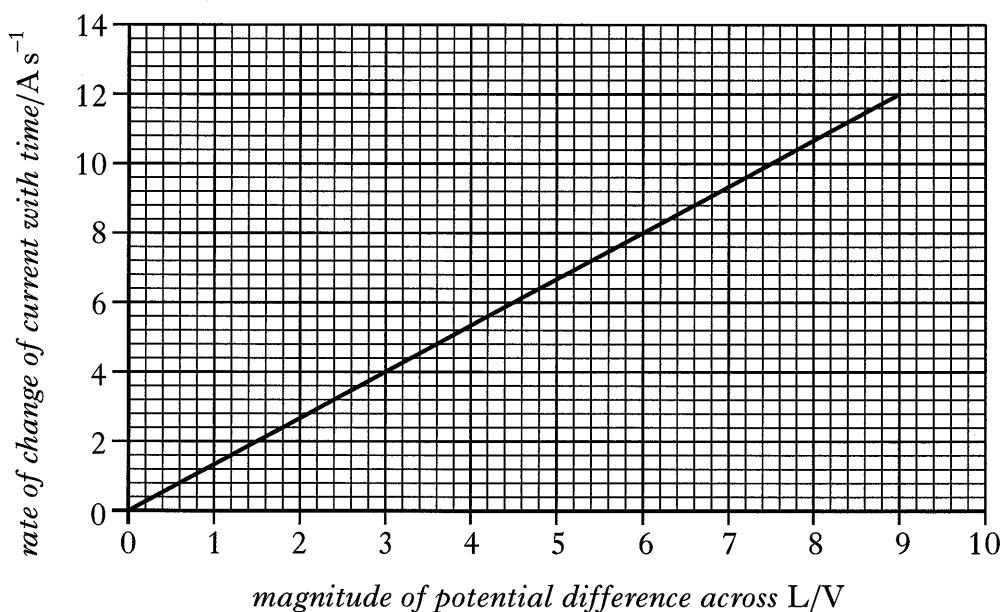

Figure 13

- Assuming that the resistance of the inductor is negligible, calculate its inductance. 2
- (c) The current in the circuit eventually reaches a steady value of 100 mA.
 Calculate the energy stored in the magnetic field of the inductor. 2
- (d) The diode in the circuit is necessary to protect the datalogger against the high voltage which can arise when the switch S is opened.
 Explain why this high voltage is produced. 1

(6)

9. (a) According to modern particle theory, protons and neutrons are composed of combinations of up and down quarks. Up quarks have a charge of $+\frac{2}{3}e$ while down quarks have a charge of $-\frac{1}{3}e$.

(i) Name the force which holds the quarks together in protons and neutrons.

1

(ii) State the combination of up and down quarks which make up:

(A) a proton;

(B) a neutron.

2

(b) A neutron can decay into a proton, electron and antineutrino.

Name the force associated with this decay.

1

(c) A thermal neutron has a velocity of $3.5 \times 10^3 \text{ m s}^{-1}$.

Calculate the de Broglie wavelength of this neutron.

2

(6)

[Turn over

10. In an experiment to measure the speed of sound in air, a loudspeaker, a signal generator and a reflector are set up as shown in Figure 14.

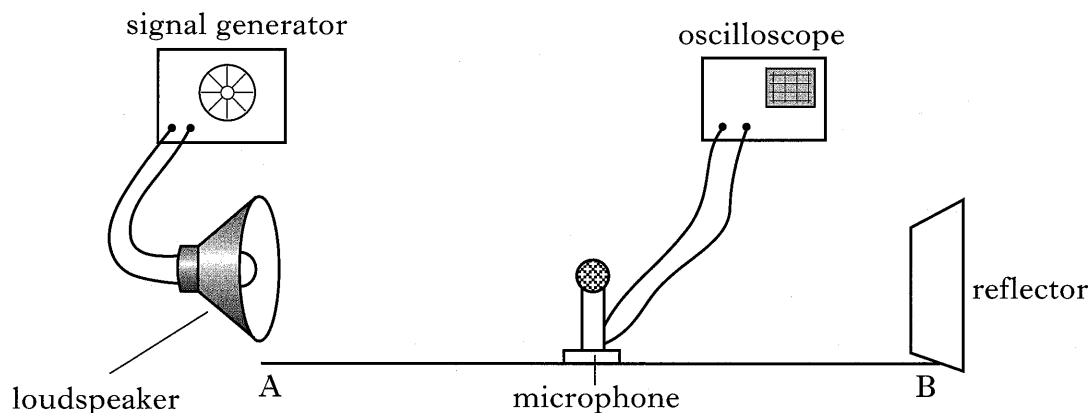

Figure 14

A stationary wave pattern is produced between the loudspeaker and the reflector. The intensity of the sound is monitored using a microphone connected to an oscilloscope. The microphone is moved steadily along line AB and the oscilloscope indicates alternate maximum and minimum values of sound intensity.

- (a) What name is given to the points in the stationary wave pattern at which **minimum** values of sound intensity occur? 1
- (b) The signal generator is adjusted until the frequency of the sound produced is 2000 Hz. The distance between two successive points of minimum sound intensity is measured as 88 mm.
- (i) Use this data to calculate the speed of sound in air. 3
- (ii) Suggest **one** improvement to the experiment which would result in a more accurate value for the speed of sound in air.

Justify your answer. 2

- (c) The microphone is placed at a position of minimum sound intensity. Without moving the microphone, the reflector is moved away from the loudspeaker until a minimum is again detected.

The intensity of sound at this minimum is found to be **greater** than the intensity of sound before the reflector was moved.

Explain this observation. 2

(8)

11. (a) An air wedge is formed between two flat glass plates of length l , which are in contact at one end. They are separated by a human hair of diameter d at the other end, as shown in Figure 15.

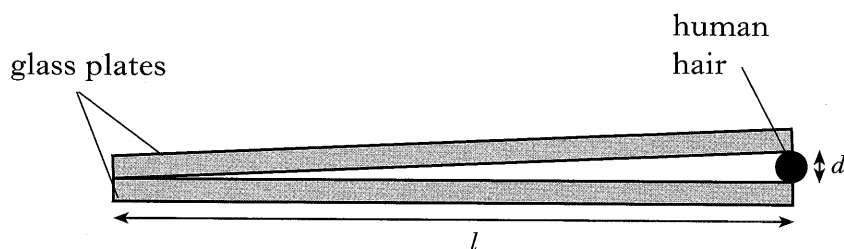

Figure 15

The air wedge is illuminated from above by a monochromatic light source of wavelength λ . When viewed from above a series of interference fringes of separation Δx is observed.

- (i) Use this information to derive an expression for the diameter of the human hair. 2
- (ii) The wavelength of the monochromatic light is 589 nm, the length of the glass plates is 75 mm and the separation between two adjacent dark fringes is 3.4×10^{-4} m.
- Calculate the diameter of the hair. 1
- (b) A camera lens can be made non-reflecting by coating it with a thin layer of magnesium fluoride.
- (i) Calculate the thickness of magnesium fluoride required to make the lens non-reflecting for light of wavelength 548 nm. 2
- (ii) The lens has a thin film of transparent liquid placed on its surface as shown in Figure 16. The refractive index of the liquid is 1.45.

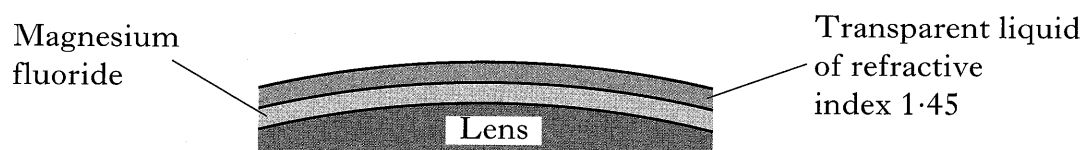

Figure 16

- Explain why the coating is no longer non-reflective. 2
- (c) Explain why coloured fringes can be observed when a thin film of oil forms on a puddle of water. 1

(8)

[END OF QUESTION PAPER]

[BLANK PAGE]

[BLANK PAGE]

[BLANK PAGE]