

X069/301

NATIONAL
QUALIFICATIONS
2002

WEDNESDAY, 22 MAY
1.00 PM – 3.30 PM

PHYSICS
HIGHER

Read Carefully

- 1 All questions should be attempted.

Section A (questions 1 to 20)

- 2 Check that the answer sheet is for Physics Higher (Section A).
- 3 Answer the questions numbered 1 to 20 on the answer sheet provided.
- 4 Fill in the details required on the answer sheet.
- 5 Rough working, if required, should be done only on this question paper, or on the first two pages of the answer book provided—**not** on the answer sheet.
- 6 For each of the questions 1 to 20 there is only **one** correct answer and each is worth 1 mark.
- 7 Instructions as to how to record your answers to questions 1–20 are given on page three.

Section B (questions 21 to 30)

- 8 Answer questions numbered 21 to 30 in the answer book provided.
- 9 Fill in the details on the front of the answer book.
- 10 Enter the question number clearly in the margin of the answer book beside each of your answers to questions 21 to 30.
- 11 Care should be taken to give an appropriate number of significant figures in the final answers to calculations.



DATA SHEET
COMMON PHYSICAL QUANTITIES

<i>Quantity</i>	<i>Symbol</i>	<i>Value</i>	<i>Quantity</i>	<i>Symbol</i>	<i>Value</i>
Speed of light in vacuum	c	$3.00 \times 10^8 \text{ m s}^{-1}$	Mass of electron	m_e	$9.11 \times 10^{-31} \text{ kg}$
Magnitude of the charge on an electron	e	$1.60 \times 10^{-19} \text{ C}$	Mass of neutron	m_n	$1.675 \times 10^{-27} \text{ kg}$
Gravitational acceleration	g	9.8 m s^{-2}	Mass of proton	m_p	$1.673 \times 10^{-27} \text{ kg}$
Planck's constant	h	$6.63 \times 10^{-34} \text{ J s}$			

REFRACTIVE INDICES

The refractive indices refer to sodium light of wavelength 589 nm and to substances at a temperature of 273 K.

<i>Substance</i>	<i>Refractive index</i>	<i>Substance</i>	<i>Refractive index</i>
Diamond	2.42	Water	1.33
Crown glass	1.50	Air	1.00

SPECTRAL LINES

<i>Element</i>	<i>Wavelength/nm</i>	<i>Colour</i>	<i>Element</i>	<i>Wavelength/nm</i>	<i>Colour</i>
Hydrogen	656	Red	Cadmium	644	Red
	486	Blue-green		509	Green
	434	Blue-violet		480	Blue
	410	Violet	<i>Lasers</i>		
	397	Ultraviolet	<i>Element</i>	<i>Wavelength/nm</i>	<i>Colour</i>
	389	Ultraviolet	Carbon dioxide	9550 } 10590 }	Infrared
Sodium	589	Yellow	Helium-neon	633	Red

PROPERTIES OF SELECTED MATERIALS

<i>Substance</i>	<i>Density/ kg m⁻³</i>	<i>Melting Point/ K</i>	<i>Boiling Point/ K</i>
Aluminium	2.70×10^3	933	2623
Copper	8.96×10^3	1357	2853
Ice	9.20×10^2	273
Sea Water	1.02×10^3	264	377
Water	1.00×10^3	273	373
Air	1.29
Hydrogen	9.0×10^{-2}	14	20

The gas densities refer to a temperature of 273 K and a pressure of $1.01 \times 10^5 \text{ Pa}$.

SECTION A

For questions 1 to 20 in this section of the paper, an answer is recorded on the answer sheet by indicating the choice A, B, C, D or E by a stroke made in ink in the appropriate box of the answer sheet—see the example below.

EXAMPLE

The energy unit measured by the electricity meter in your home is the

- A ampere
- B kilowatt-hour
- C watt
- D coulomb
- E volt.

The correct answer to the question is B—kilowatt-hour. Record your answer by drawing a heavy vertical line joining the two dots in the appropriate box on your answer sheet in the column of boxes headed B. The entry on your answer sheet would now look like this:

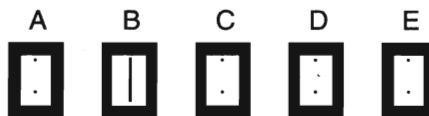

If after you have recorded your answer you decide that you have made an error and wish to make a change, you should cancel the original answer and put a vertical stroke in the box you now consider to be correct. Thus, if you want to change an answer D to an answer B, your answer sheet would look like this:

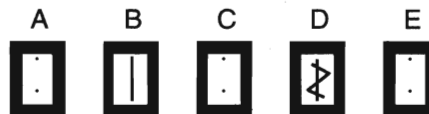

If you want to change back to an answer which has already been scored out, you should enter a tick (✓) to the RIGHT of the box of your choice, thus:



SECTION A

Answer questions 1–20 on the answer sheet.

1. The following graph shows how the displacement of an object varies with time.

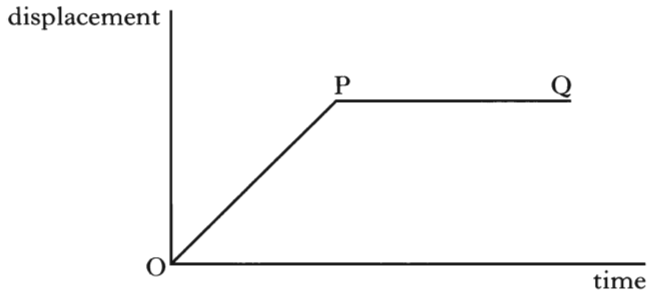

Which row of the table below best describes the motion of this object?

	<i>From O to P</i>	<i>From P to Q</i>
A	constant acceleration	constant velocity
B	zero velocity	constant deceleration
C	constant velocity	zero velocity
D	zero velocity	constant velocity
E	constant velocity	constant deceleration

2. Which of the following velocity-time graphs best describes a ball being thrown vertically into the air and returning to the thrower's hand?

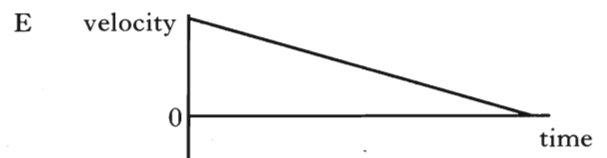
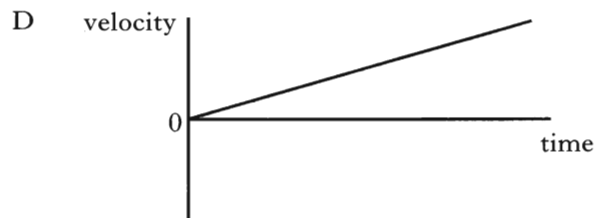
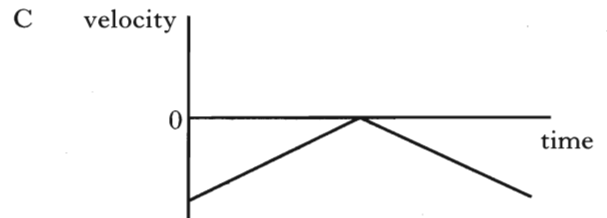
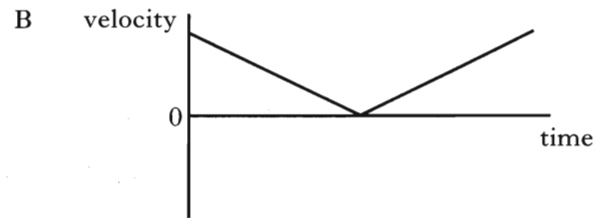
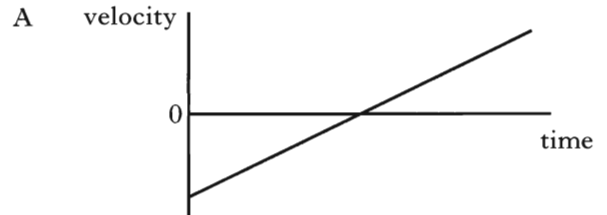

3. A force of 180 N is applied vertically upwards to a box of mass 15 kg.

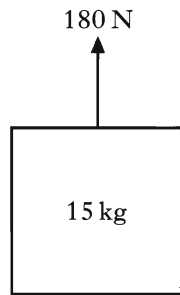

Assuming that the acceleration due to gravity is 9.8 m s^{-2} , the acceleration of the box is

- A 2.2 m s^{-2}
- B 7.6 m s^{-2}
- C 9.8 m s^{-2}
- D 12.0 m s^{-2}
- E 19.6 m s^{-2} .

4. A box of mass 10 kg rests on an inclined plane. The component of the weight of the box acting down the incline is 50 N. A force of 300 N, parallel to the plane, is applied to the box as shown.

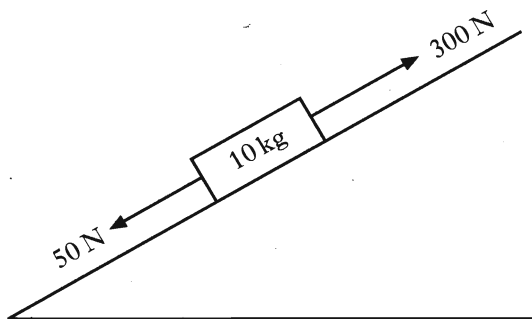

The box accelerates at 10 m s^{-2} up the plane.

The size of the force of friction opposing the motion of the box is

- A 50 N
- B 100 N
- C 150 N
- D 200 N
- E 250 N.

5. A flat bottomed test-tube containing aluminium rivets is floated in liquid A.

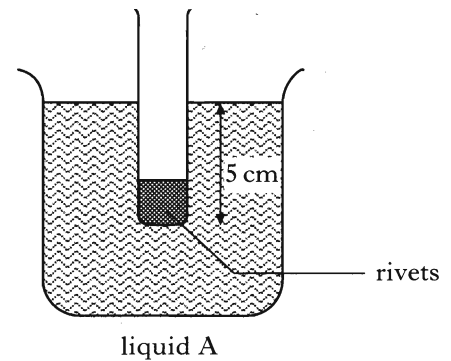

The bottom of the test-tube is at a depth of 5 cm below the surface.

The same test-tube and aluminium rivets are then floated in liquid B.

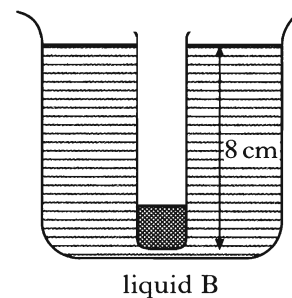

The bottom of the test-tube is at a depth of 8 cm below the surface.

Which of the following statement(s) is/are true?

- I In each liquid the pressure at the bottom of the test-tube is the same.
- II The density of liquid A is greater than the density of liquid B.
- III In each liquid the upthrust on the bottom of the test-tube is the same.

- A I only
- B II only
- C I and II only
- D II and III only
- E I, II and III

[Turn over

6. A helium filled balloon of mass 1.5 kg floats at a constant height of 100 m. The acceleration due to gravity is 9.8 ms^{-2} .

The upthrust on the balloon is

- A 0 N
- B 1.5 N
- C 14.7 N
- D 150 N
- E 1470 N.

7. A sealed hollow buoy drifts from warm Atlantic waters into colder Arctic waters.

The volume of the buoy remains constant.

The pressure of the air trapped inside the buoy changes.

This is because the pressure of the trapped air is

- A directly proportional to the kelvin temperature
- B inversely proportional to the kelvin temperature
- C inversely proportional to the volume of the air in the buoy
- D inversely proportional to the celsius temperature
- E directly proportional to the celsius temperature.

8. In the following circuit the current from the battery is 3 A.

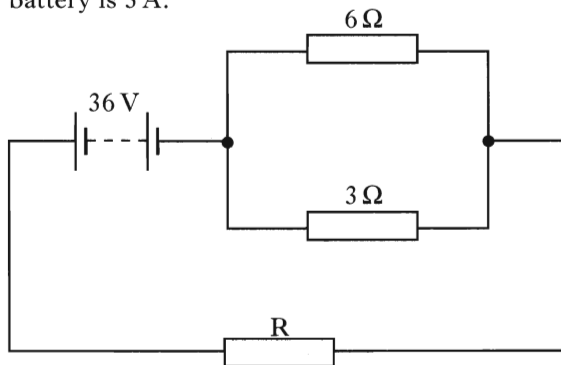

Assuming that the battery has negligible internal resistance, the resistance of resistor R is

- A 3Ω
- B 4Ω
- C 10Ω
- D 12Ω
- E 18Ω .

9. The diagram below shows a balanced Wheatstone bridge where all the resistors have different values.

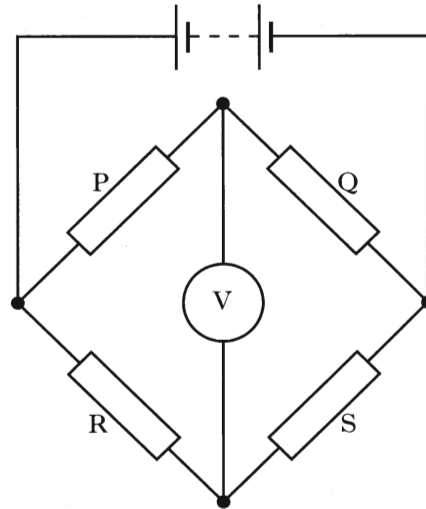

Which change(s) would make the bridge unbalanced?

- I Interchange resistors P and S.
- II Interchange resistors P and Q.
- III Change the e.m.f. of the battery.

- A I only
- B II only
- C III only
- D II and III only
- E I and III only

10. A student sets up the following circuit.

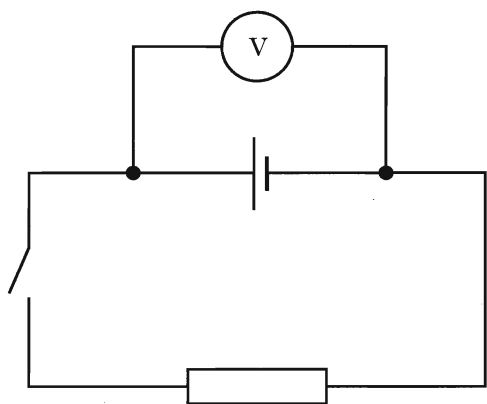

When the switch is open, the student notes that the reading on the voltmeter is 1.5 V. The switch is then closed and the reading falls to 1.3 V.

The decrease of 0.2 V is referred to as the

- A e.m.f.
- B lost volts
- C peak voltage
- D r.m.s. voltage
- E terminal potential difference.

11. The unit for capacitance can be written as

- A VC^{-1}
- B CV^{-1}
- C Js^{-1}
- D CJ^{-1}
- E JC^{-1} .

12. Which of the following statements about capacitors is/are true?

- I Capacitors are used to block a.c. signals.
- II Capacitors are used to block d.c. signals.
- III Capacitors can store energy.
- IV Capacitors can store electric charge.

- A I only
- B I and III only
- C II and III only
- D II, III and IV only
- E III and IV only

13. The operational amplifier connected in the circuit below is powered by a supply of +15 V and -15 V.

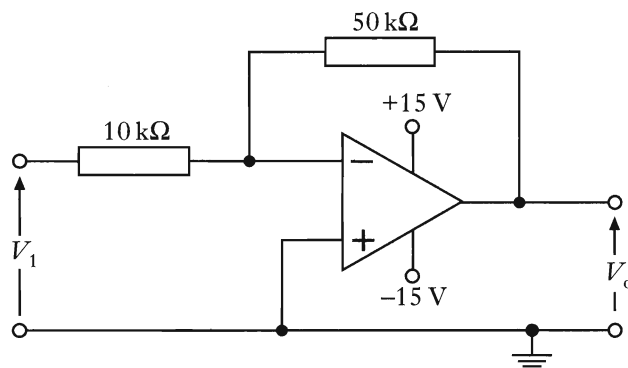

The input voltage V_1 is +5 V. The most likely value for the output voltage V_0 is

- A -25 V
- B -13 V
- C -1 V
- D +13 V
- E +25 V.

14. The amplifier shown below has an output voltage of 5.0 V.

Input voltage V_1 is originally 0.5 V and input voltage V_2 is originally 0.6 V.

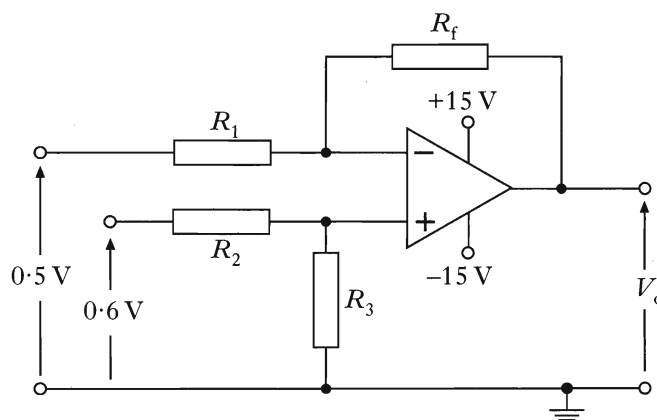

$$R_1 = R_2 \text{ and } R_f = R_3$$

The input voltages V_1 and V_2 are increased to 1.0 V and 1.2 V respectively.

The output voltage V_0 is now

- A 0.2 V
- B 2.2 V
- C 5.0 V
- D 6.0 V
- E 10 V.

15. Microwave radiation is incident on a metal plate which has 2 slits, P and Q. A microwave receiver is moved from R to S, and detects a series of maxima and minima of intensity at the positions shown.

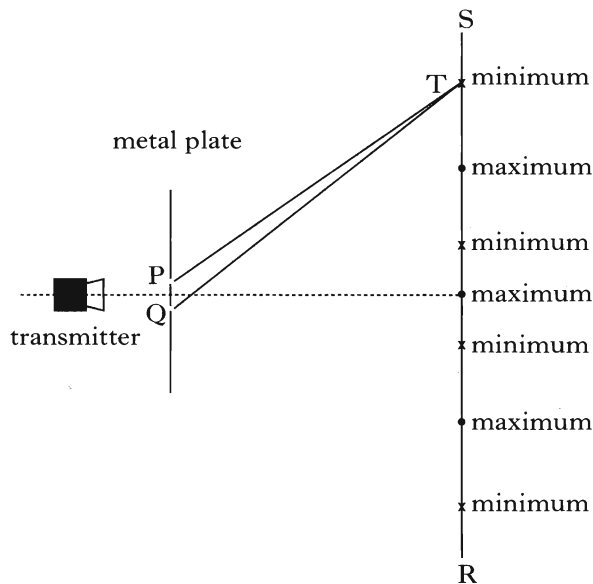

The microwave radiation has a wavelength of 4 cm.

The path difference between PT and QT is

- A 2 cm
 B 3 cm
 C 4 cm
 D 5 cm
 E 6 cm.
16. Light of frequency 5.0×10^{14} Hz passes from air into a block of glass of refractive index 1.5.

Which row in the following table gives the correct values for the velocity, frequency and wavelength of the light in the glass?

	<i>velocity</i> /m s ⁻¹	<i>frequency</i> /Hz	<i>wavelength</i> /m
A	2.0×10^8	5.0×10^{14}	4.0×10^{-7}
B	3.0×10^8	5.0×10^{14}	6.0×10^{-7}
C	3.0×10^8	3.3×10^{14}	6.0×10^{-7}
D	2.0×10^8	3.3×10^{14}	6.0×10^{-7}
E	3.0×10^8	3.3×10^{14}	4.0×10^{-7}

17. In a laser, a photon of radiation is emitted when an electron makes a transition from a higher energy level to a lower level, as shown below.

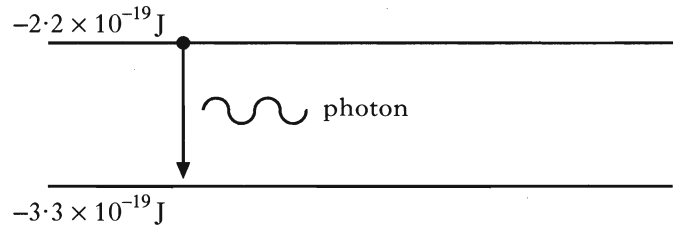

The energy in each pulse of radiation from the laser is 10 J. How many photons are there in each pulse?

- A 1.8×10^{19}
 B 3.0×10^{19}
 C 3.7×10^{19}
 D 4.5×10^{19}
 E 9.1×10^{19}

18. In a darkened room, a small lamp is placed 2 cm from a photodiode which is connected in the circuit as shown. The lamp may be regarded as a point source. The reading on the ammeter is $27 \mu\text{A}$.

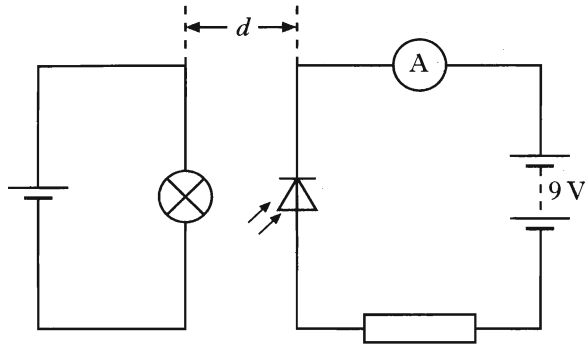

Which graph shows correctly how the ammeter reading changes as the distance d between the lamp and the photodiode is increased to 6 cm?

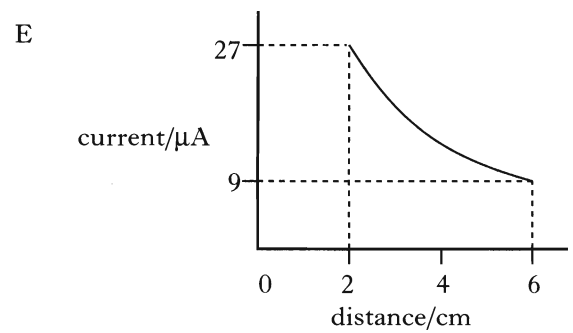
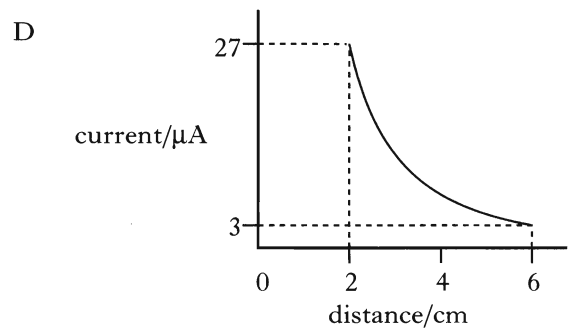
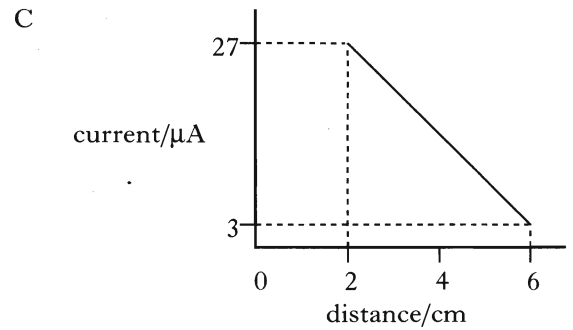
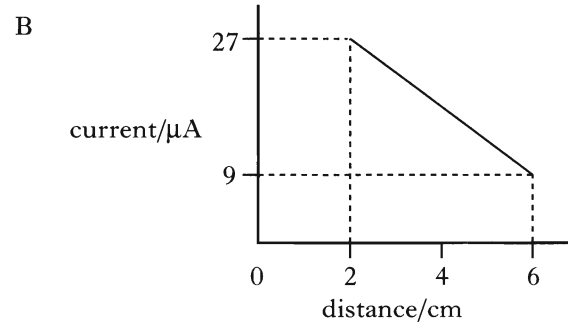
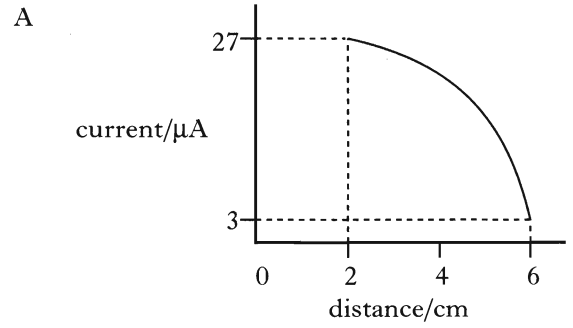

19. Which row of the table shows the correct values of x , y and z for the nuclear reaction described below?

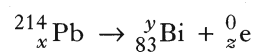

	x	y	z
A	84	214	1
B	83	210	4
C	85	214	2
D	82	214	-1
E	82	210	-1

20. The risk of biological harm from exposure to radiation depends on

- I the absorbed dose
- II the body organs exposed
- III the type of radiation.

Which statement(s) is/are true?

- A I only
- B II only
- C III only
- D II and III only
- E I, II and III

[SECTION B begins on *Page twelve*]

SECTION B

Write your answers to questions 21 to 30 in the answer book.

21. A basketball is held below a motion sensor. The basketball is released from rest and falls onto a wooden block. The motion sensor is connected to a computer so that graphs of the motion of the basketball can be displayed.

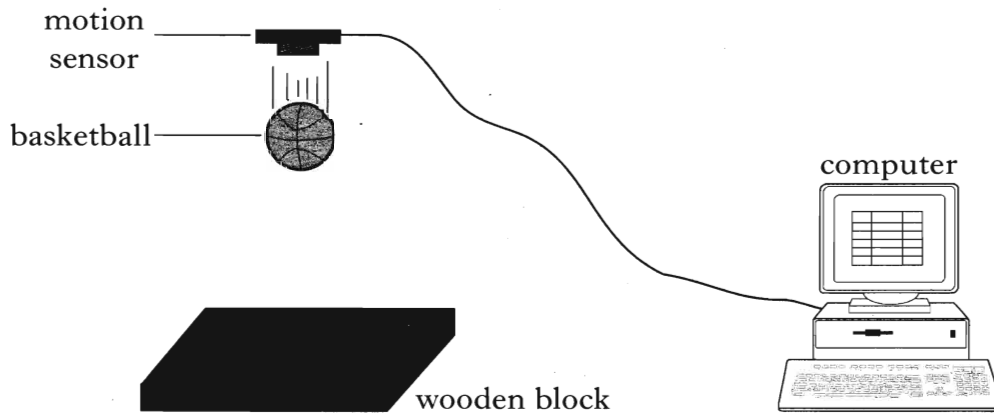

A displacement-time graph for the motion of the basketball from the instant of its release is shown.

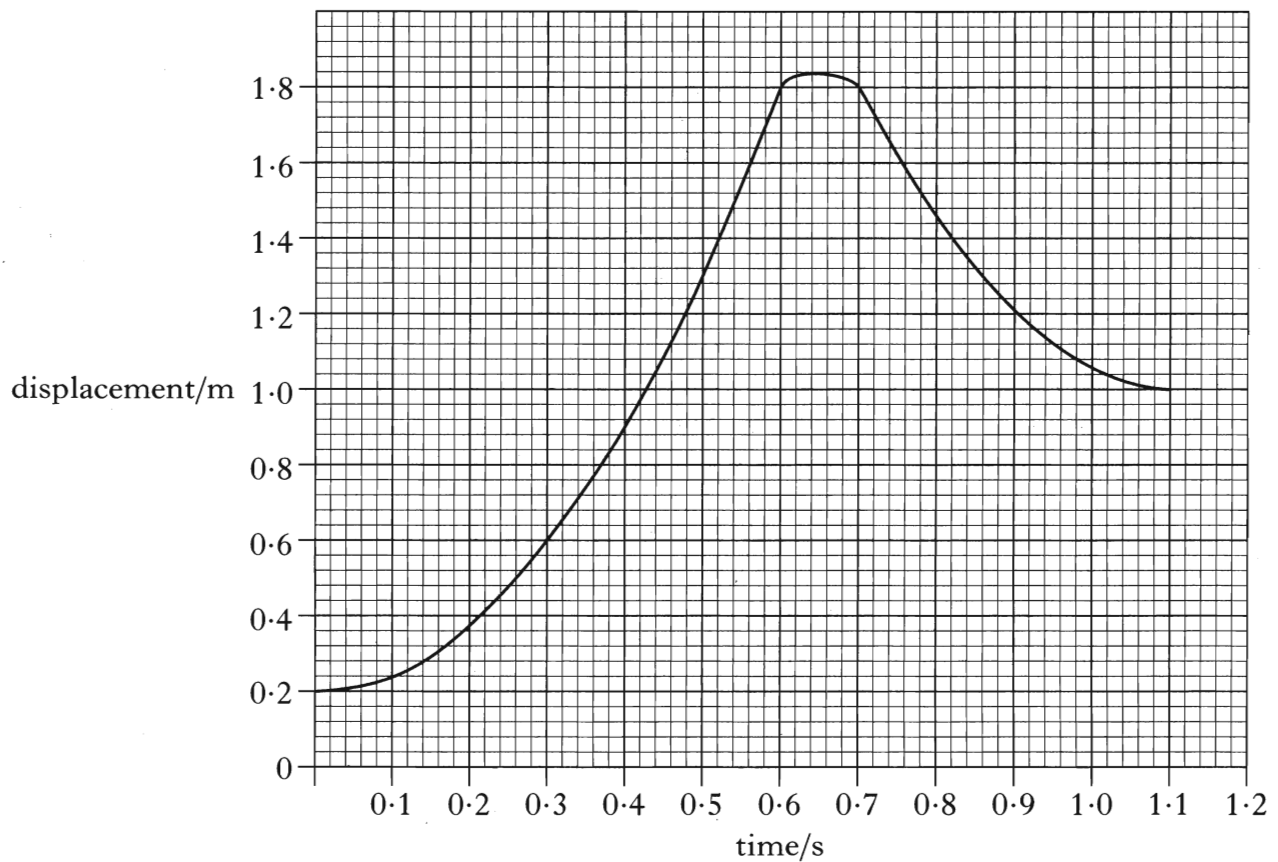

21. (continued)

- (a) (i) What is the distance between the motion sensor and the top of the basketball when it is released?
- (ii) How far does the basketball fall before it hits the wooden block?
- (iii) Show, by calculation, that the acceleration of the basketball as it falls is 8.9 m s^{-2} .

3

- (b) The basketball is now dropped several times from the same height. The following values are obtained for the acceleration of the basketball.

8.9 m s^{-2} 9.1 m s^{-2} 8.4 m s^{-2} 8.5 m s^{-2} 9.0 m s^{-2}

Calculate:

- (i) the mean of these values;
- (ii) the approximate random uncertainty in the mean.
- (c) The wooden block is replaced by a block of sponge of the same dimensions. The experiment is repeated and a new graph obtained. Describe and explain any **two** differences between this graph and the original graph.

3

2

(8)

[Turn over

22. A technician designs the apparatus shown in the diagram to investigate the relationship between the temperature and pressure of a fixed mass of nitrogen which is kept at a constant volume.

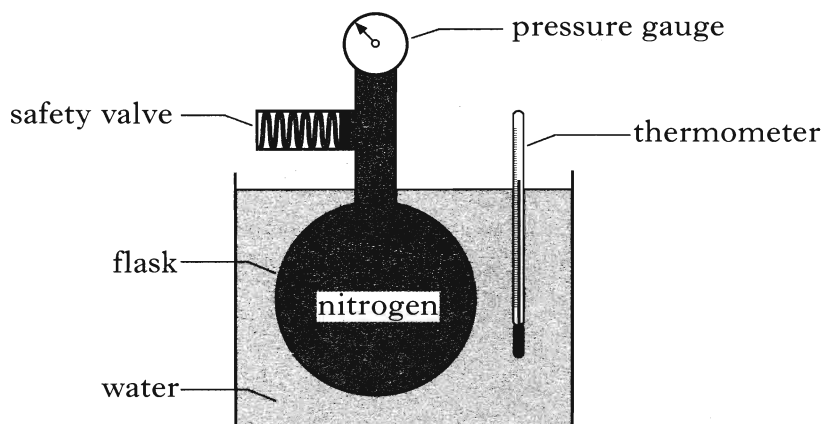

- (a) The pressure of the nitrogen is 109 kPa when its temperature is 15 °C. The temperature of the nitrogen rises to 45 °C.

Calculate the new pressure of the nitrogen in the flask.

2

- (b) Explain, in terms of the movement of gas molecules, what happens to the pressure of the nitrogen as its temperature is increased.

2

- (c) The technician has fitted a safety valve to the apparatus.

A diagram of the valve is shown below.

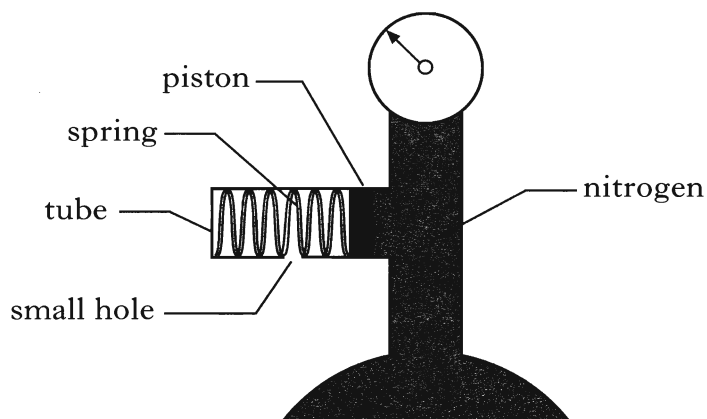

The piston of cross-sectional area $4.0 \times 10^{-6} \text{ m}^2$ is attached to the spring. The piston is free to move along the tube.

The following graph shows how the length of the spring varies with the force exerted by the nitrogen on the piston.

22. (c) (continued)

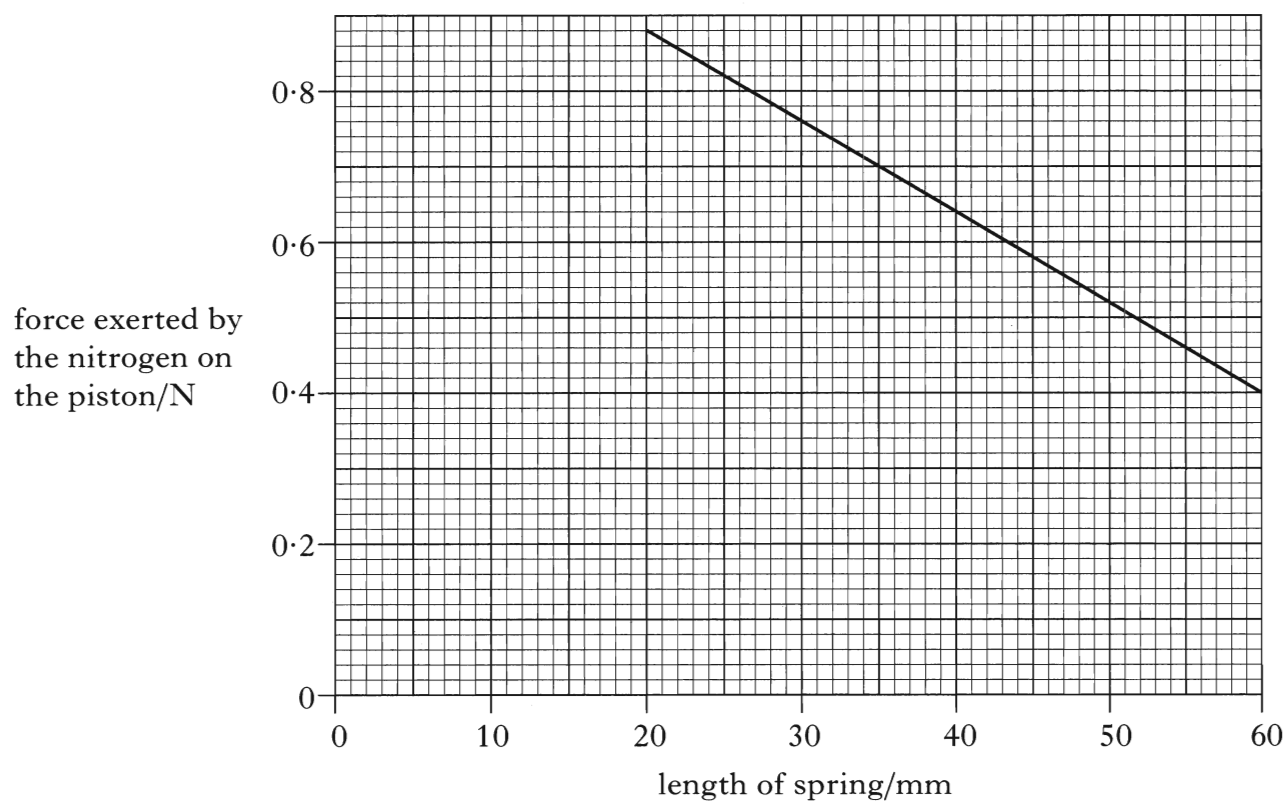

- (i) Calculate the force exerted by the nitrogen on the piston when the reading on the pressure gauge is $1.75 \times 10^5 \text{ Pa}$.
- (ii) What is the length of the spring in the safety valve when the pressure of the nitrogen is $1.75 \times 10^5 \text{ Pa}$?
- (d) The technician decides to redesign the apparatus so that the bulb of the thermometer is placed inside the flask.
- Give **one** reason why this improves the design of the apparatus.

3

1

(8)

[Turn over

23. (a) A space vehicle of mass 2500 kg is moving with a constant speed of 0.50 m s^{-1} in the direction shown. It is about to dock with a space probe of mass 1500 kg which is moving with a constant speed in the opposite direction.

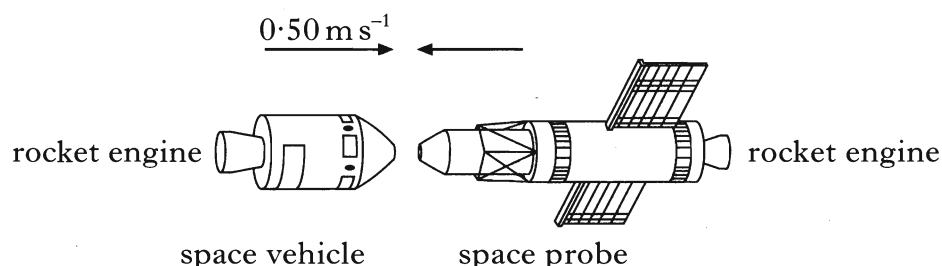

After docking, the space vehicle and space probe move off together at 0.20 m s^{-1} in the original direction in which the space vehicle was moving.

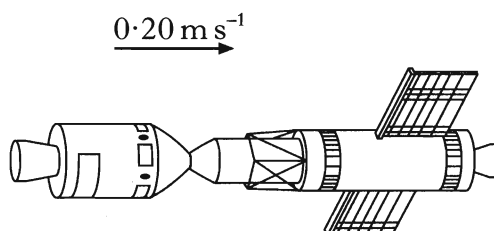

Calculate the speed of the space probe before it docked with the space vehicle.

2

- (b) The space vehicle has a rocket engine which produces a constant thrust of 1000 N. The space probe has a rocket engine which produces a constant thrust of 500 N.

The space vehicle and space probe are now brought to rest from their combined speed of 0.20 m s^{-1} .

- Which rocket engine was switched on to bring the vehicle and probe to rest?
- Calculate the time for which this rocket engine was switched on. You may assume that a negligible mass of fuel was used during this time.

3

- (c) The space vehicle and space probe are to be moved from their stationary position at A and brought to rest at position B, as shown.

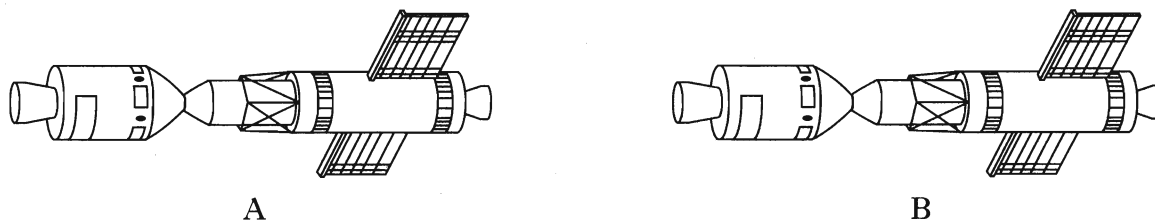

Explain clearly how the rocket engines of the space vehicle and the space probe are used to complete this manoeuvre.

Your explanation must include an indication of the relative time for which each rocket engine must be fired.

You may assume that a negligible mass of fuel is used during this manoeuvre.

2

24. A battery has an e.m.f. of 6.0 V and internal resistance of 2.0 Ω.

(a) What is meant by an *e.m.f. of 6.0 V*?

1

(b) The battery is connected in series with two resistors, R_1 and R_2 . Resistor R_1 has a resistance of 20 Ω.

The reading on the ammeter is 200 mA.

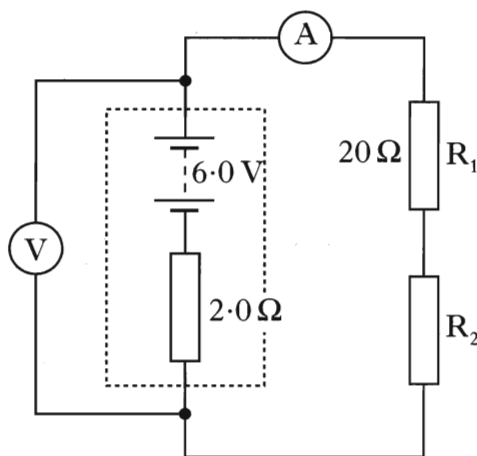

(i) Show by calculation that R_2 has a resistance of 8.0 Ω.

(ii) Calculate the reading on the voltmeter.

4

(c) The battery is now connected to two identical lamps as shown below.

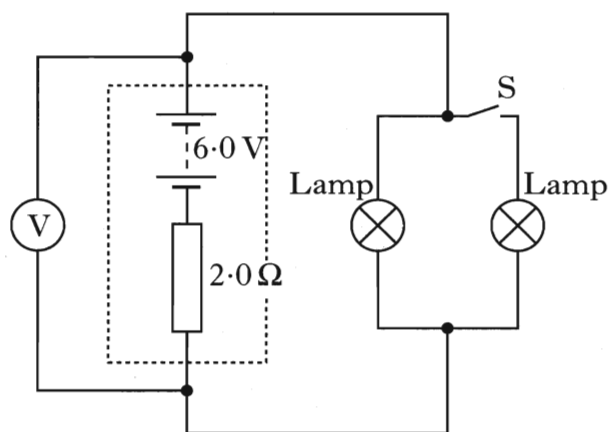

Describe and explain what happens to the reading on the voltmeter when switch S is closed.

2

(7)

[Turn over

25. (a) The circuit below is used to investigate the charging of a $2000\ \mu\text{F}$ capacitor. The d.c. supply has negligible internal resistance.

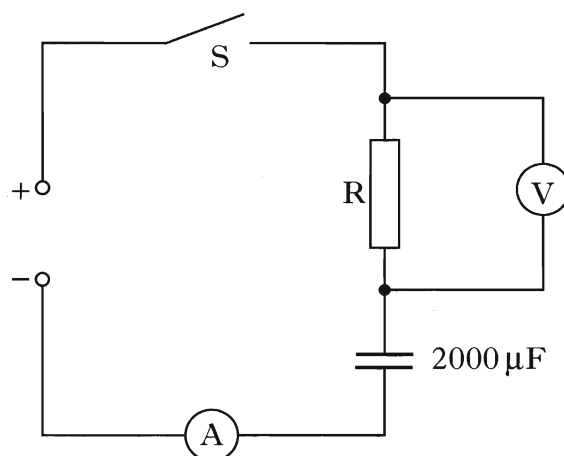

The graphs below show how the potential difference V_R across the **resistor** and the current I in the circuit vary with time from the instant switch S is closed.

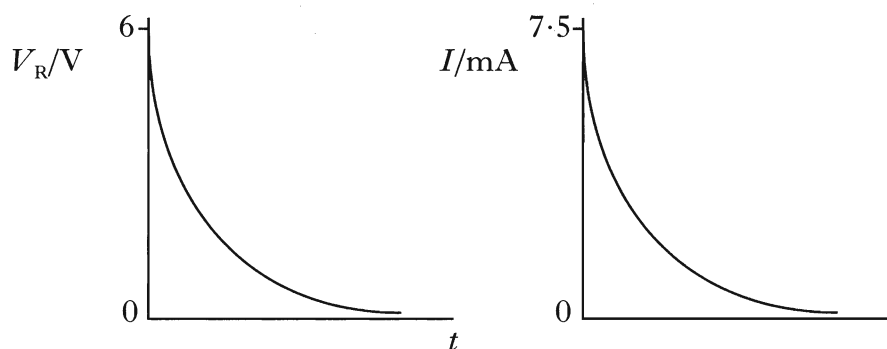

- (i) What is the potential difference across the capacitor when it is fully charged?
- (ii) Calculate the energy stored in the capacitor when it is fully charged.
- (iii) Calculate the resistance of R in the circuit above.

5

25. (continued)

(b) The circuit below is used to investigate the charging and discharging of a capacitor.

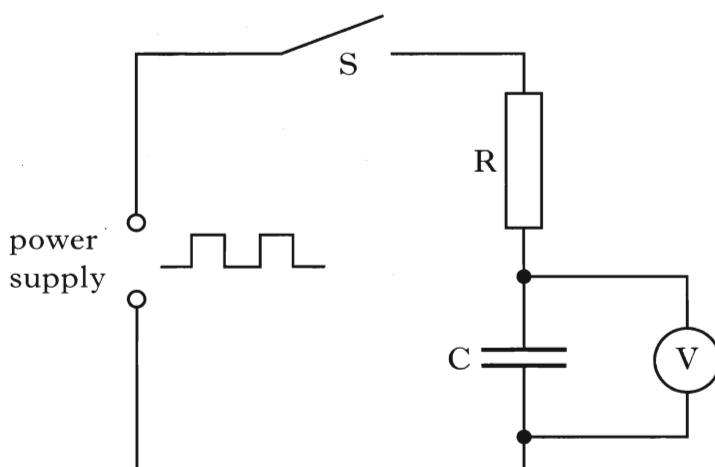

The graph below shows how the power supply voltage varies with time after switch S is closed.

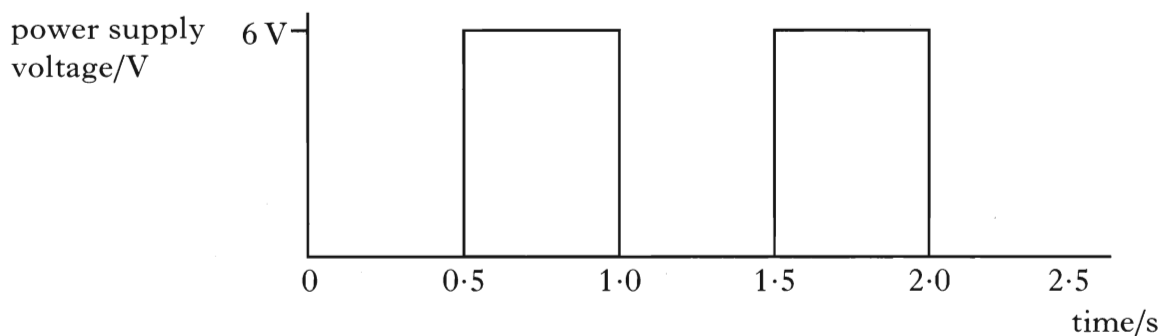

The capacitor is initially uncharged.

The capacitor charges fully in 0.3 s and discharges fully in 0.3 s.

Sketch a graph of the reading on the voltmeter for the first 2.5 s after switch S is closed.

The axes on your graph must have the same numerical values as those in the above graph.

2
(7)

[Turn over

26. An alternating voltage signal displayed on an oscilloscope screen is shown below. The peak voltage is 6.0 V and the time base setting is 2 ms/cm.

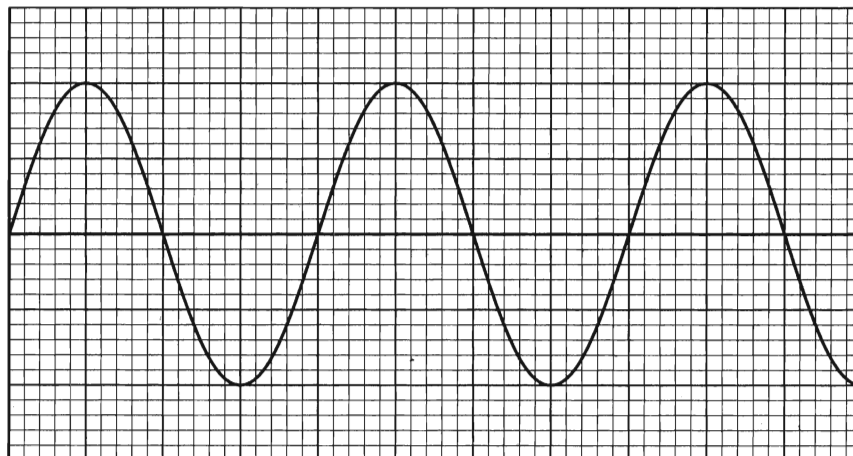

- (a) Calculate the frequency of the signal. 2
- (b) This alternating voltage is used as the input voltage V_1 for the operational amplifier circuit shown below. R_f is a variable resistor.

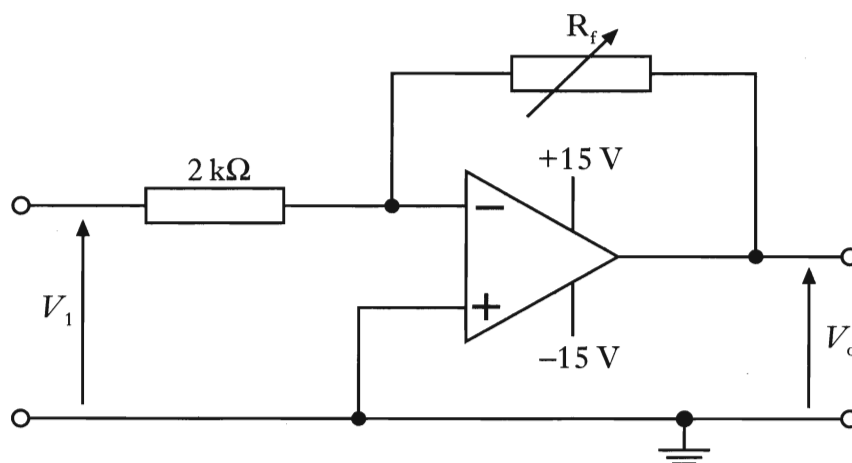

- (i) In what mode is the operational amplifier operating?
- (ii) The variable resistor R_f is set at 3.0 k Ω .
- (A) On square ruled paper, sketch a graph of the output voltage V_o . Numerical values must be shown.
- (B) Calculate the **r.m.s.** value of the output voltage V_o .
- (iii) The resistance of resistor R_f is gradually increased from 3 k Ω to 8 k Ω . Describe what happens to the output voltage V_o during this time.

7
(9)

27. A ray of red light is directed at a glass prism of side 80 mm as shown in the diagram below.

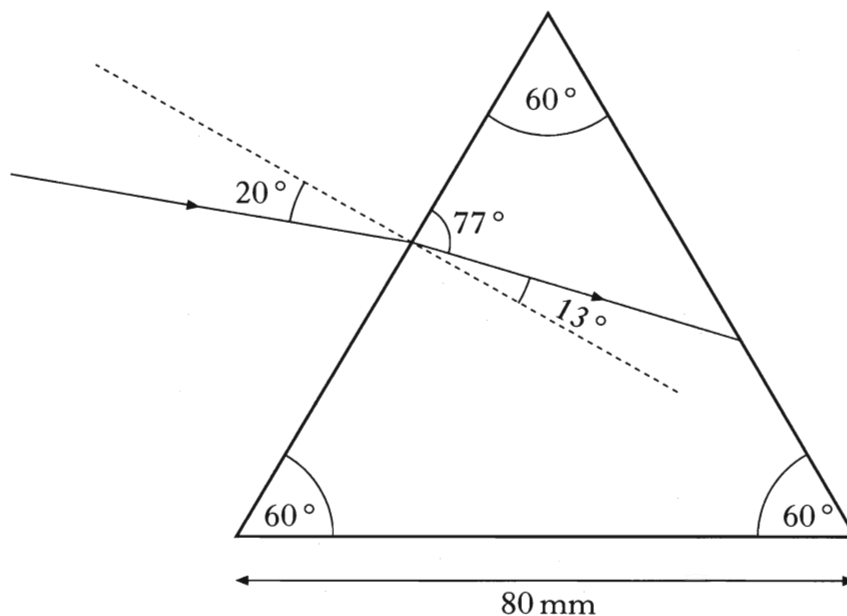

- (a) Using information from this diagram, show that the refractive index of the glass for this red light is 1.52. 1
- (b) What is meant by the term *critical angle*? 1
- (c) Calculate the critical angle for the red light in the prism. 2
- (d) Sketch a diagram showing the path of the ray of red light until after it leaves the prism. Mark on your diagram the values of all relevant angles. 3
- (7)

[Turn over

28. An image intensifier is used to improve night vision. It does this by amplifying the light from an object.

Light incident on a photocathode causes the emission of photoelectrons. These electrons are accelerated by an electric field and strike a phosphorescent screen causing it to emit light. This emitted light is of a greater intensity than the light that was incident on the photocathode.

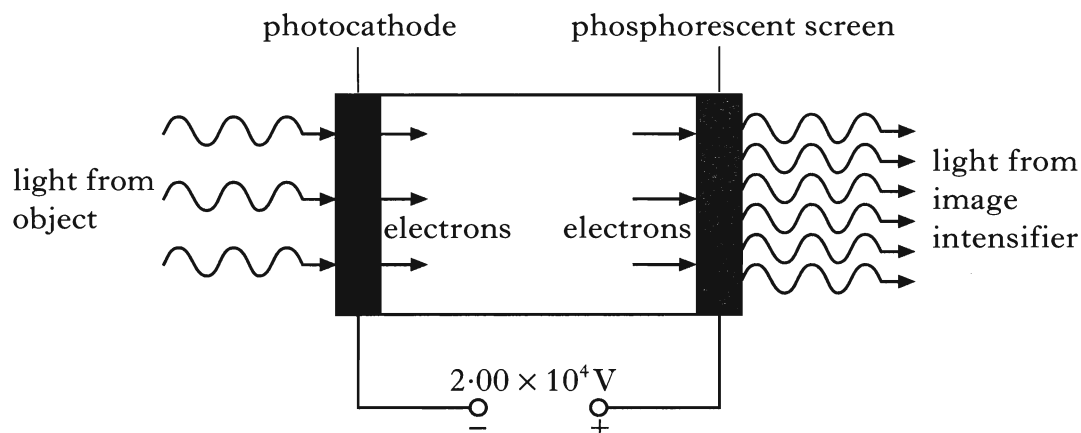

The voltage between the photocathode and the phosphorescent screen is $2.00 \times 10^4 \text{V}$.

The minimum frequency of the incident light that allows photoemission to take place is $3.33 \times 10^{14} \text{Hz}$.

- (a) What name is given to the minimum frequency of the light required for photoemission to take place? 1
- (b) (i) Show that the work function of the photocathode material is $2.21 \times 10^{-19} \text{J}$.
- (ii) Light of frequency $5.66 \times 10^{14} \text{Hz}$ is incident on the photocathode. Calculate the maximum kinetic energy of an electron emitted from the photocathode.
- (iii) Calculate the kinetic energy gained by an electron as it is accelerated from the photocathode to the phosphorescent screen. 6

(7)

29. (a) A sample of pure semiconducting material is doped by adding impurity atoms.

How does this addition affect the resistance of the semiconducting material?

1

- (b) The circuit below shows a p-n junction diode used as a light emitting diode (LED).

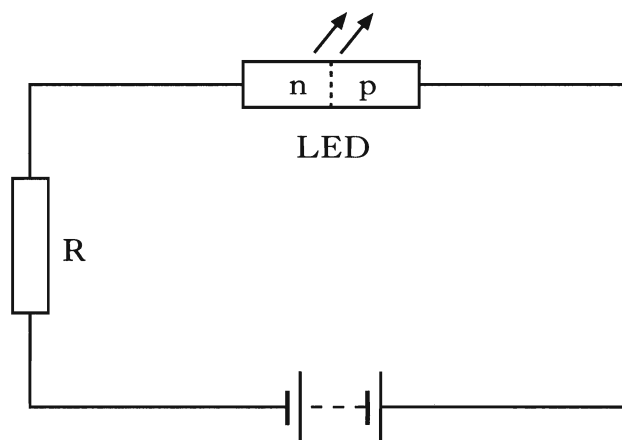

- (i) Explain in terms of the charge carriers how the LED emits light.
 (ii) Monochromatic light from the LED is incident on a grating as shown.

The spacing between lines in the grating is 5.0×10^{-6} m.

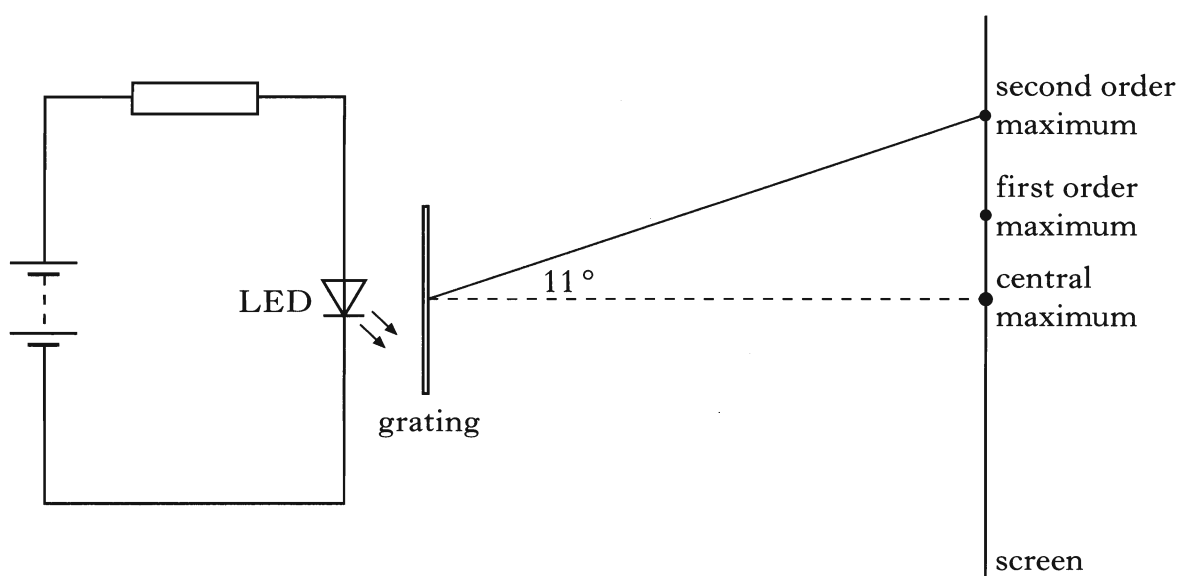

What is the wavelength of the light emitted by the LED?

4

(5)

[Turn over for Question 30 on Page twenty-four

30. (a) Torbernite is a mineral which contains uranium.

The activity of 1.0 kg of pure torbernite is 5.9×10^6 decays per second.

A sample of material of mass 0.6 kg contains 40% torbernite. The remaining 60% of the material is not radioactive.

What is the activity of the sample in becquerels?

2

(b) The table below gives the quality factor for some types of radiation.

<i>Type of radiation</i>	<i>Quality factor</i>
Gamma rays	1
Fast neutrons	10
Alpha particles	20

Exposure to $150 \mu\text{Gy}$ of alpha particles for 6 hours gives the same dose equivalent rate as exposure for 8 hours to $400 \mu\text{Gy}$ of one of the other radiations in the table above.

Identify this radiation.

You must justify your answer by calculation.

3

(5)

[END OF QUESTION PAPER]